

Design-5

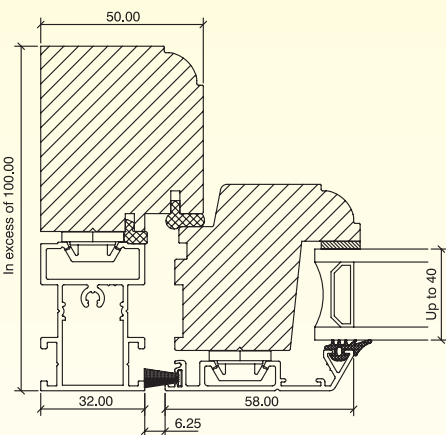

Our aluminium sections are supplied to a number of joinery manufacturers so individual pleasing aesthetic shapes and details are available subject to order size.

COLOUR CHOICE
External aluminium is available in the full range of RAL and BS powder paint colours.



USING RAW MATERIALS FROM SUSTAINABLE SOURCES



ENVIRONMENTALLY FRIENDLY

- a high proportion of the aluminium used in this product is from recycled material
- dependant on timber specified, FSC accreditation is available
- we only use water based timber treatments

SERVICES

- Project references, including a vast choice of high quality and varied installation examples, from hundreds of satisfied clients
- Information to assist in product selection
- Comprehensive technical support

Research & Development

AM's in-house design team ensures the company stays at the forefront of product innovation. Our research and development programme is on-going and rigorous.

Testing

All of our products are independently tested. Please contact the Technical Department to request a full copy of any specific reports.

Bespoke sections

Our experienced technical team offers in-house product development and we are happy to discuss the production of bespoke sections to your design.

CAD drawings

Section drawings and assemblies can be sent by e-mail in a suitable format. Alternatively they are available as hard copy, or on CD/disc.



AM Profiles Ltd., Hardwick View Road, Holmewood Industrial Estate, Holmewood, Chesterfield, Derbyshire S42 5SA, England
Tel: +44 (0)1246 856 000 Fax: +44 (0)1246 855 105
sales@amprofiles.com www.amprofiles.com



Due to our policy of continued product improvement we reserve the right to change designs and specifications without prior notice.

THE NATURAL BEAUTY
OF TIMBER ON THE INSIDE AND...
THE STRENGTH AND RESILIENCE
OF ALUMINIUM ON THE OUTSIDE

Design-5

Timber / Aluminium Composite Window System

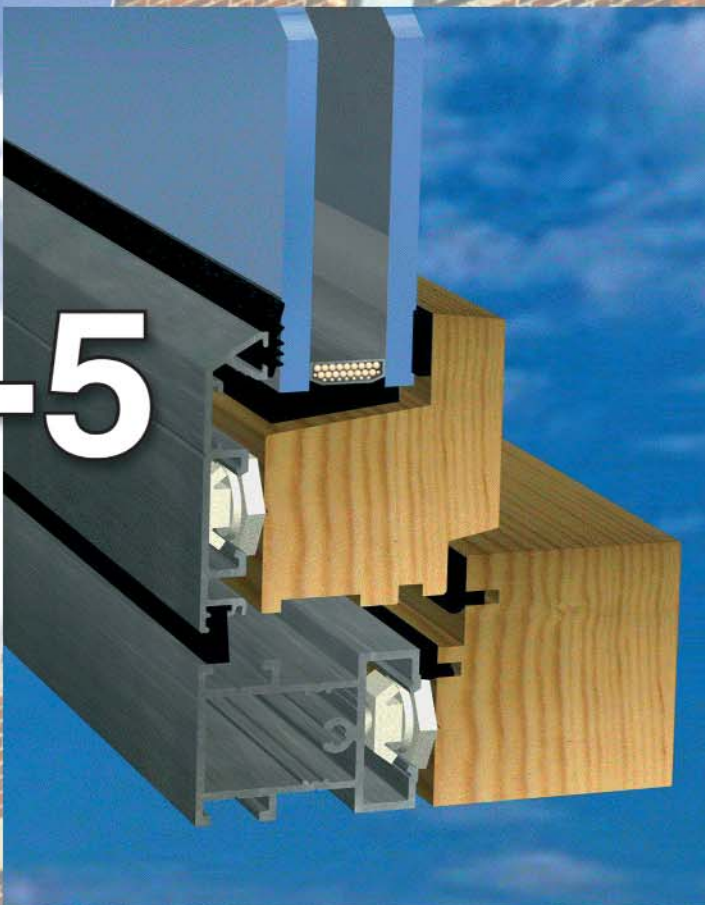

DESIGNED WITH NATURE'S
RESOURCES IN MIND BY



Design-5

The window system that offers the traditional beauty of natural timber on the inside and the strength, resilience and colour possibilities of aluminium on the outside.

Advanced technology and performance values combined with traditional British qualities of workmanship

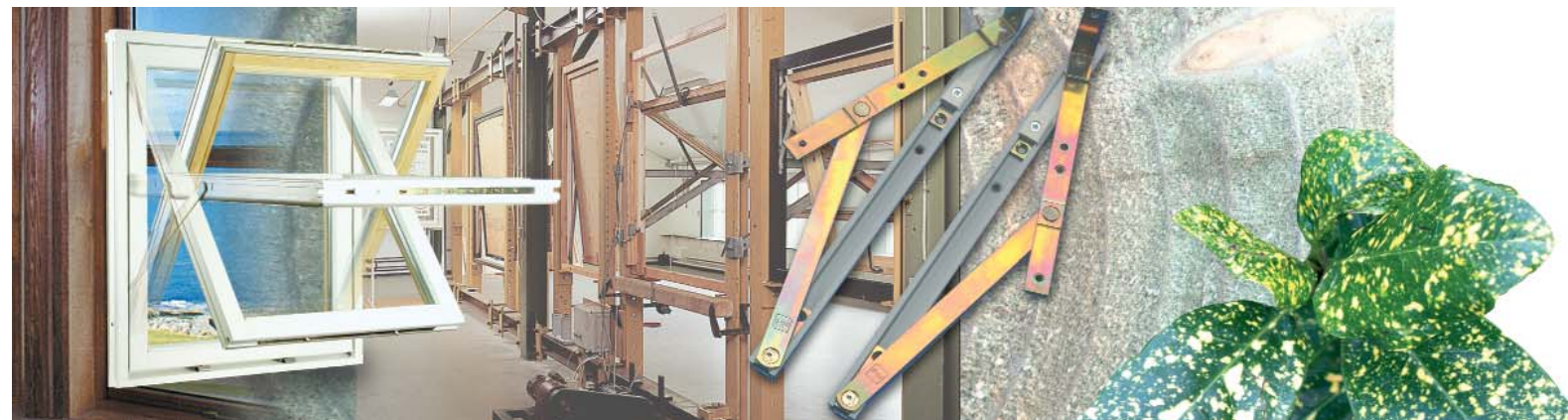

Design-5 is a new range of aluminium sections, exclusively available from AM Profiles. The new aluminium profiles have been designed to clip to the front of timber windows to create a cost effective and high performance timber aluminium composite system.

Design-5 offers a choice of opening styles, external colour and internal timber shape and finish.

- Traditional timber construction with aluminium cladding sections.
- Designed to accommodate PN Combi hinge system.
- 6mm gap between sash and frame maintained with any sash type.
- Aluminium corners and transom/mullions mechanically connected.
- Concealed drainage.
- All areas can be externally or internally glazed.
- Timber section designs can be tailored to aesthetic 'taste'.
- Multi-point espagnolette locking.
- Security tested to BS7950.
- High performance weather tested.
- Excellent thermal performance.
- High acoustic performance - dependant on glass specification.

AM Profiles is a Secured-By-Design License holder



The market for timber aluminium composite windows is expanding so AM Profiles is pleased to provide a range of aluminium cladding sections for the joinery industry. Medium to large sized timber window fabricators can now add timber aluminium clad composite windows to their 'standard' range. With Design-5 it is possible to produce a wide range of open out windows. The extrusions have been designed to house the PN Combi 500 system. Open out windows that can be made with the system are illustrated below.

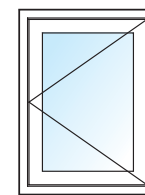

Design-1
Projecting side hung (or side hung on butt hinges).

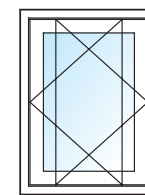

Design-2
Side swing reversible.

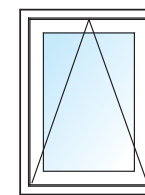

Design-3
Projecting top hung (or top hung on butt hinges).

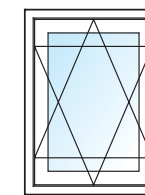

Design-4
Top swing reversible.

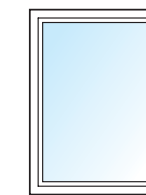

Design-5
Inside or outside beaded fixed areas.

Combinations of sash opening types and fixed light areas are easy to accommodate within the same window and the system has been designed to facilitate glazing from the inside or outside dependant on the requirements of the project.

Universally matching sight lines are maintained even when top or side swing fully reversible and top or side hung casement sashes are housed within the same outerframe.

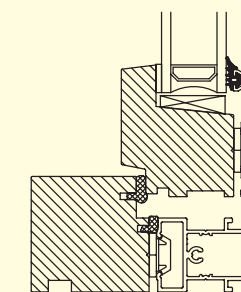
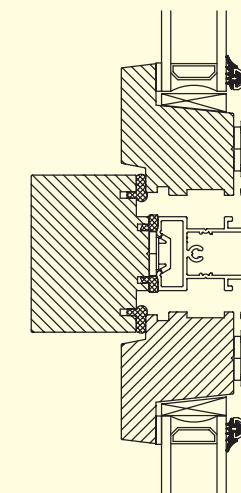
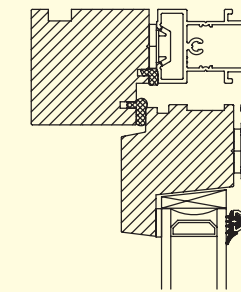

Offering a variety of open out sash types including casement and top / side swing reversible in the same frame, the Design-5 window offers clean crisp sight line uniformity.

FEATURES OF THIS INNOVATIVE BRITISH TIMBER ALUMINIUM COMPOSITE SYSTEM

- external aluminium in the full range of RAL and BS powder paint colours.
- wide choice of internal timbers with opaque or clear finishes.
- available from a network of approved fabricators and installers.
- door and screen system.
- high quality standard hardware.
- window sash handles set below the glass line.
- extensive choice of window types.

